

MADDEN PUMP

JN SERIES DIAPHRAGM METERING PUMP OPERATING MANUAL AND PARTS LIST

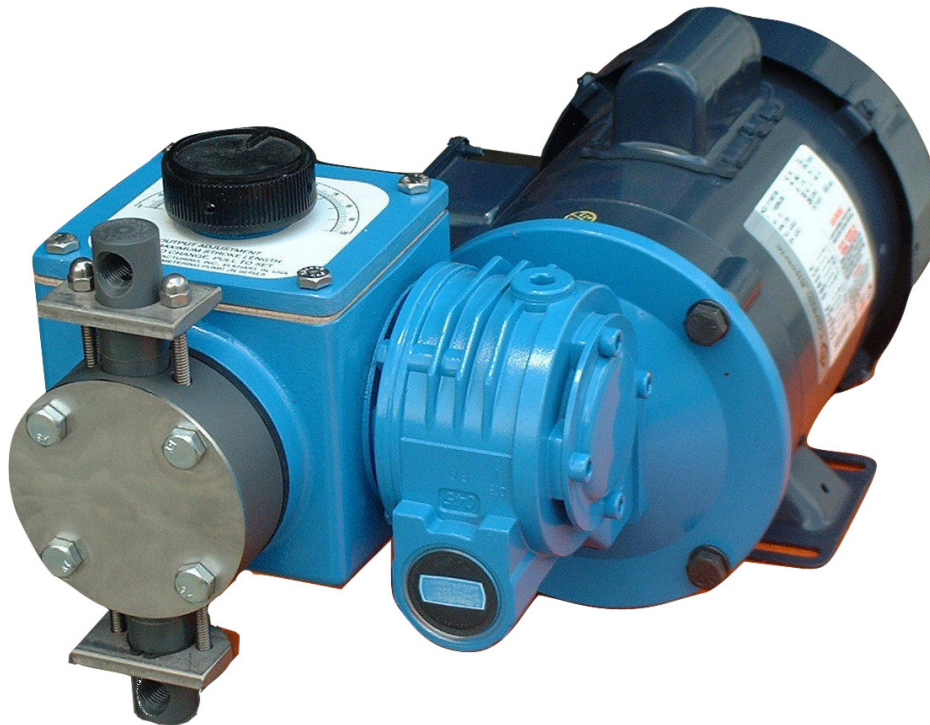

MADDEN Pump
P.O. Box 387 • 1317 Princeton Blvd. Elkhart, IN 46515 USA
Phone: 574-295-4292 • FAX: 574-295-7562
E-mail: info@maddenpump.com • Website: www.maddenpump.com

JN Series Diaphragm Metering Pump

JN SERIES PUMPS OPERATORS MANUAL AND PARTS LIST

SPECIFICATIONS

The Madden JN Series diaphragm type metering pumps are designed for controlled volume chemical pumping, for 24 hours a day, 365 days a year service. There are six models in the JN Series pump family; the table below details the capacity of each model. Maximum pressure is 250 psi with a metal wetted end installed. With a plastic wetted end construction the maximum pressure rating is 150 psi.

Model no.	Max psi	Output Min-max @ 100 PSI, 1725 rpm motor GPH (LPH)	Output Min-max 2400 rpm GPH
JN101A	250	0.13-1.3 (.49-4.9)	0.1-1.5
JN102A	250	0.21-2.1 (.79-7.9)	0.1-3.1
JN104A	250	0.4-4.0 (1.5-15.1)	0.1-4.9
JN105A	250	0.48-4.8 (1.8-18.2)	0.1-6.7
JN107A	250	0.72-7.2 (2.7-27.2)	0.1-8.4
JN111A	250	1.10-11 (4.2-42)	0.1-11

OPERATION PRINCIPLES

The pump sucks liquid into the solution head through the lower check valve assembly when the spring pushes the piston and diaphragm rearward. The motor driven worm gear and spur gear transmission rotates the drive shaft with the eccentric pushing the piston forward on the discharge portion of the stroke. As the piston pushes the diaphragm the liquid inside the solution head is pressurized, closing the lower inlet check valve, and opening the upper outlet check valve allowing the liquid to pass through the pump into the discharge piping.

The stroke adjustment knob located on the top of the pump has a pointer and index numbers from 0 to 100, with the 100 setting being the maximum output of the pump. To reduce the pump output, loosen thumb screw, push the adjustment knob down and rotate the knob so the pointer moves from 100 to a lower index number. The knob is connected to a precision ground cam inside the pump that reduces the length of the piston travel as the knob is moved to lower index numbers. After the knob has been turned pull the knob up and tighten thumb screw to maintain the adjustment knob position. The normal adjustment range is from 100 down to 10 on the index scale. Operating in this range will produce pumping repeatable accuracy of +/- 1%. Turning the knob below 10 will continue to reduce the pump output, but the amount of variation in output will also increase.

Due to the small clearances in the check valves the JN Series pumps can not handle liquids with suspended solids or liquids over 400 cps viscosity.

INSTALLATION PROTOCOL

1. Inspection and mounting

Your pump has been inspected and performance tested

at the factory. Visually inspect the pump to make sure there has been no shipping damage. If there has been damage, do not operate the pump. Contact the factory or the local sales representative. If the pump is not damaged mount the pump with bolts securely to a firm foundation that will support the weight of the pump and attached piping, and that will withstand operating vibrations.

2. Wiring

Have an electrician check the electrical power wiring to the motor to make sure the wiring is properly installed per the motor wiring diagram. Make sure there is adequate electrical power supply for the motor and that electrical safety controls are installed.

3. Piping

- Inspect piping installation for these items:
- Correct size and materials for piping. Also confirm that the pump application is the same as when the pump was ordered, and that the wetted end materials of the pump construction are suitable for the liquid being pumped.
 - Suction and discharge piping installed in proper connection on the pump: suction connection is on the bottom and the discharge connection is on the top.
 - A suction side filter is recommended to keep solids from interfering with valve operation.
 - Accessory fittings are installed as required
 - Accessories required may include any of the following items: pressure relief valve, back pressure valve, suction side filter and valves, pulsation dampener, foot valve with filter, calibration column, leak detector switch or leak containment for double diaphragm type pumps.

4. Lubrication

Your pump comes from the factory filled to the proper level with lubrication. If you notice oil leakage in the shipping carton or on the pump that occurred in shipping you may check to make sure the pump has adequate lubrication. Carefully scribe a line in two places from the top to the pump body to enable you to precisely replace the top. Then remove the top plate by removing the four hex head screws. Lubrication should be filled to the level of the middle of the drive shaft. If the oil level is low add more lubricant. The lubricant should be ISO 460 grade general purpose lubricant purchased from an industrial lubricant distributor. To drain the oil remove the top plate and turn the pump upside down. The oil should be replaced only when it is contaminated.

5. Leaks

Your pump was pressure tested at the factory for leaks. After the pump is installed check the pump and piping for leaks by pumping water or other inert liquid through the system under pressure or by using compressed air. **WARNING: DO NOT OPERATE THE PUMP AGAINST A DEAD HEAD.** Tighten all leaking connections. Check the pump solution head bolts and valve cap flange bolts

JN Series Diaphragm Metering Pump

JN SERIES PUMPS OPERATORS MANUAL AND PARTS LIST

for tightness. Tighten pump bolts if they are not tight. *CAUTION, OVER TIGHTENING THE BOLTS OR PIPING COULD CAUSE DAMAGE AS THREADS MAY BECOME STRIPPED.* During the first six weeks of pump operation check the tightness of the solution head bolts once a week and tighten as required to prevent leakage. The rubber diaphragm will creep due to the pump action and that can cause leaks if the bolts are not checked and tightened periodically.

6. Calibration

The table on page 1 shows the output range of your pump with water. However, you will need to calibrate your pump and prepare a calibration curve in order to know the exact output rate of your pump at various stroke length and motor speed settings (for those pumps with variable speed motors). When the pump is shipped from the factory the output adjustment knob is set at 100. Measure the amount of liquid flowing through the pump by using a calibration column or supply tank with volume markings. Determine the amount of liquid being pumped over a short period of time (usually 1 minute) at various stroke settings. Record your data and plot a calibration curve showing output at the various stroke settings.

7. Repairs and service

Set up a file folder for your pump to include the operating manual and parts list. Record the pump model number and serial number. If the invoice for the pump is available include it as it may have other useful data. Read the operators manual and parts list and follow the instructions. Obtain a list of recommended spares for the pump and keep the spares in stock for future use. Set up a preventive maintenance inspection and service schedule and keep a record of the service in the file.

PRIMING THE PUMP

We recommend arranging the pump and supply tank to provide a flooded suction if possible, with the shortest suction side piping between the tank and the pump. As the full stroke displacement of the pump is 2.86 ml it will take some time to displace the air in the suction line to enable the liquid to flow freely. It may be advisable to fill the suction line with liquid before installing the line to the pump to remove the air. If the pump must be located over the supply tank requiring a suction lift the pump will pull up to 10 feet. However, in a suction lift condition it is recommended that a foot valve be installed at the end of the suction line to keep liquid in the suction tube when the pump is not running. Adding a tee and vertical pipe spud reaching above the pump head will allow priming liquid to be poured into the suction line to enable the pump to start up more rapidly.

MOTOR

The standard motor supplied is industrial grade 56C frame 1/3 HP, 1,725 rpm, TEFC, with 1/60/115-230 power. Many other motors are available for different power and motor enclosure requirements. Variable

speed motors are available in 1,725 and 2,400 rpm speeds that can be used with variable speed motor controllers for remote control of the pump output.

Type DDB Double Diaphragm

If the liquid being pumped is dangerous and could create a hazard to the pump or the environment in the event of a diaphragm leak then a Type DDB double diaphragm construction is recommended. This construction provides a backup diaphragm to prevent liquid from entering the pump gear case, and it has a ring to provide for visual or automatic leak detection.

DIAPHRAGM REPLACEMENT

The molded rubber diaphragm is reinforced with Nylon fabric. The short 0.090" maximum stroke length minimizes fatigue wear on the diaphragm. The service life of the diaphragm will depend on the hours of service, the liquid being pumped, temperature, pressure, and other factors. Regular scheduled inspections and replacement of a worn diaphragm will reduce pump down time.

To change the old diaphragm, follow these steps:

1. Turn off the pump and close the piping valves.
2. Remove the four bolts (JR059 or JR063) attaching the solution head to the pump body. Move the solution head outward. You may need to disconnect rigid piping.
3. Remove the old diaphragm by turning the diaphragm counter clockwise until the threaded stud has disengaged from the piston. If the end of the piston does not extend beyond the mounting face for the diaphragm rotate the motor shaft by hand until the piston outer edge is flush with the edge of the pump body.
4. Screw on a new diaphragm until it is snug. Turn it counter clockwise if necessary to line up the four bolt holes.
5. Reassemble the solution head to the pump body using the four bolts removed earlier. Do not over tighten as you might strip the threads in the aluminum pump body, or you could distort the diaphragm. Keep even pressure on the four bolts.
6. Reconnect the piping, open the valves and check for leaks. Periodically check the four bolts for tightness.

MADDEN JN Series Diaphragm Metering Pump

JN SERIES PUMPS OPERATORS MANUAL AND PARTS LIST

Help Line

If questions or problems occur during the set up or operation of your Madden pump contact your local sales representative or the Madden factory for assistance.

Phone: 574-295-4292 from 7:30 am - 4:00 pm, EST
 FAX: 574-295-7562E-mail:
 info@maddenpump.com
 Website: www.maddenpump.com

Part No.	DWG ID	Qty	Description
JN010A	A	1	Pump body, simplex
JN010B	A	1	Pump body, duplex
JN011A	B	1	Gear reducer, pump m/n. JN101A
JN011B	B	1	Gear reducer, pump m/n. JN102A
JN011C	B	1	Gear reducer, pump m/n. JN104A
JN011D	B	1	Gear reducer, pump m/n. JN105A
JN011E	B	1	Gear reducer, pump m/n. JN107A
JN011F	B	1	Gear reducer, pump m/n. JN111A
JN012A	C	1	Drive shaft, simplex
JN012B		1	Drive shaft, duplex
JN013	D	1	Output shaft cover for gear reducer
JN015	F	6	Screw, M6 x 16 mm
JN016	G	1	Bushing, bronze
JN024	H	4	Set screw, 1/4-20 x 1/4"
JN040	I	1	Eccentric
JR042	J	1	Roller bearing, for eccentric
JN044	K	1	Piston
JR045	L	1	Spring, for piston
JR046	M	1	Retainer plate, for spring
JR047	N	2	Screw, retainer plate, FH 1/4"- 20 X 1/2"
JN049	O	1	Cover assembly
JN049A	P	1	Label for top plate
JR050	Q	4	HH screw, 1/4"-20 X 3/4"
JN051	R	1	Gasket, cover
JR052	S	1	Knob, output adjustment, w/set screw
JN053	T	1	Spring for adjustment knob
JN055	U	1	Stroke adjustment cam shaft
JR056	X	1	Thumb screw, stroke adj. lock
56331C	V	1	Standard Motor, 1/3 HP, TEFC, 1/60/115-230
MP026	W	2	Woodruff key #607
JR058A	58	1	Solution head, PVC
JR058B	58	1	Solution head 316 stainless steel
JR058D	58	1	Solution head, Teflon

Part No.	DWG ID	Qty	Description
JR059	59	4	Screw, metal solution head SH 5/16-18 X 3/4"
JR060A	60	1	Diaphragm, Neoprene
JR060B	60	1	Diaphragm, Teflon faced
JR060D	60	1	Diaphragm, Viton
JR060E	60	1	Diaphragm, Hypalon
JR062	62	1	Face flange for plastic solution head
JR063	63	4	Screw, HH 5/16"-18 X 1-3/4" (for plastic solution head)
JR064	64	1	Valve flange, top
JR065	65	1	Valve flange, bottom
JR066	66	2	Screw, valve flange
JR067A	67	2	Valve body, PVC
JR067B	67	2	Valve body, 304 stainless steel
JR067D	67	2	Valve body, Teflon
JR068	68	4	Valve seat, glass filled Teflon
JR069	69	4	Valve cushion, Teflon
JR070A	70	4	Valve ball, 316 stainless steel
JR070B	70	4	Valve ball, ceramic
JR070C	70	4	Valve ball, Hastelloy C
JR072	72	2	Snap ring
JR071	71	2	Valve gasket, Inertex, Teflon
JR091A	91	1	DDB double diaphragm, backup, Neoprene
JR091D	91	1	DDB double diaphragm, backup, Viton
JR091E	91	1	DDB double diaphragm, backup, Hypalon
JR092	92	1	Spacer, DDB double diaphragm, PVC
JR093	93	1	Secondary piston for Type DDB Double Diaphragm

**MADDEN JN Series Diaphragm Metering Pump
JN SERIES PUMPS OPERATORS MANUAL AND PARTS LIST**

WETTED END ASSEMBLY

NOTE: ITEMS 91-93 ARE INCLUDED ONLY IN PUMPS HAVING A DOUBLE DIAPHRAGM CONSTRUCTION

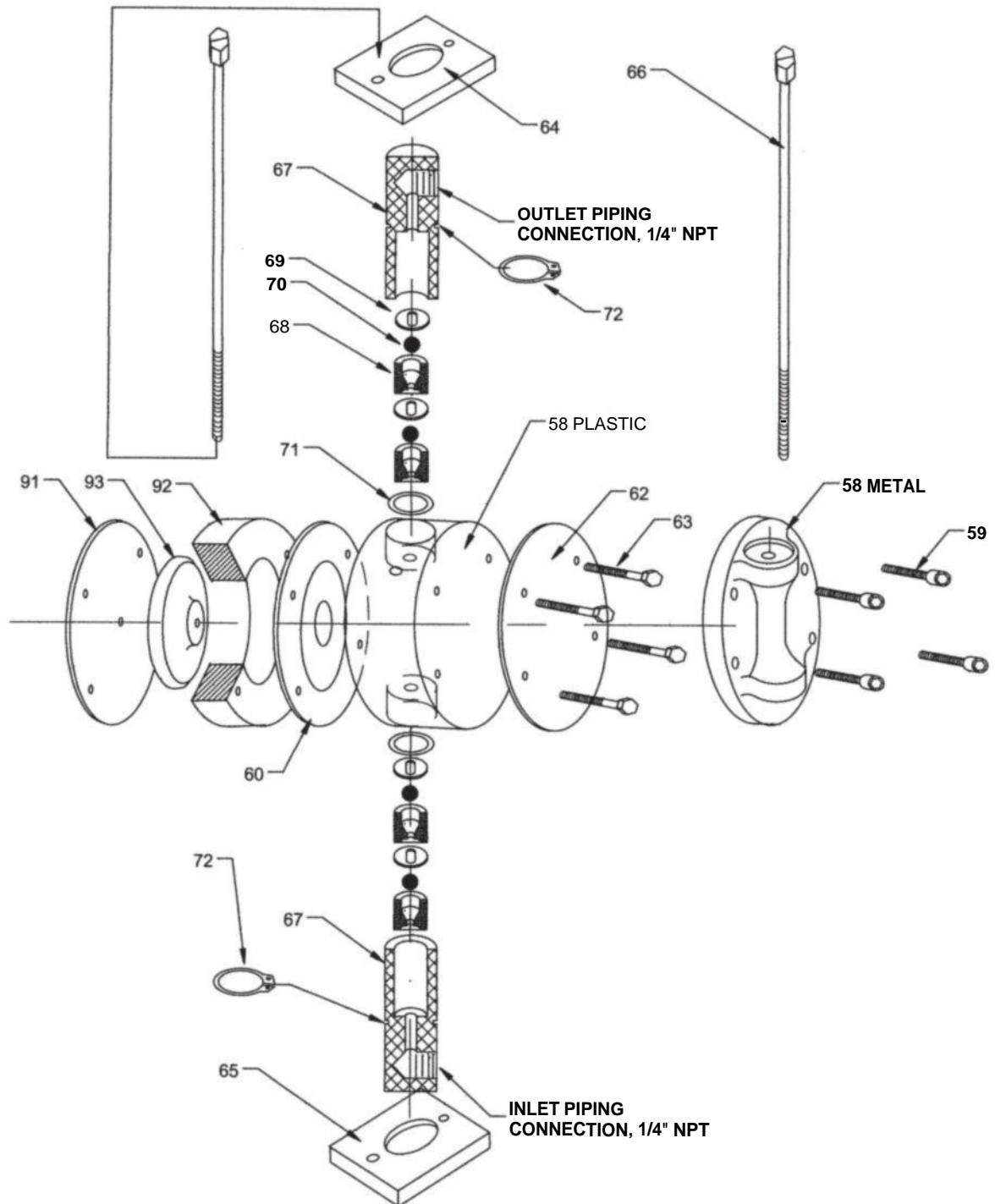

MADDEN JN SERIES PUMPS PARTS
 SHOWN WITHOUT WETTED END ASSEMBLY

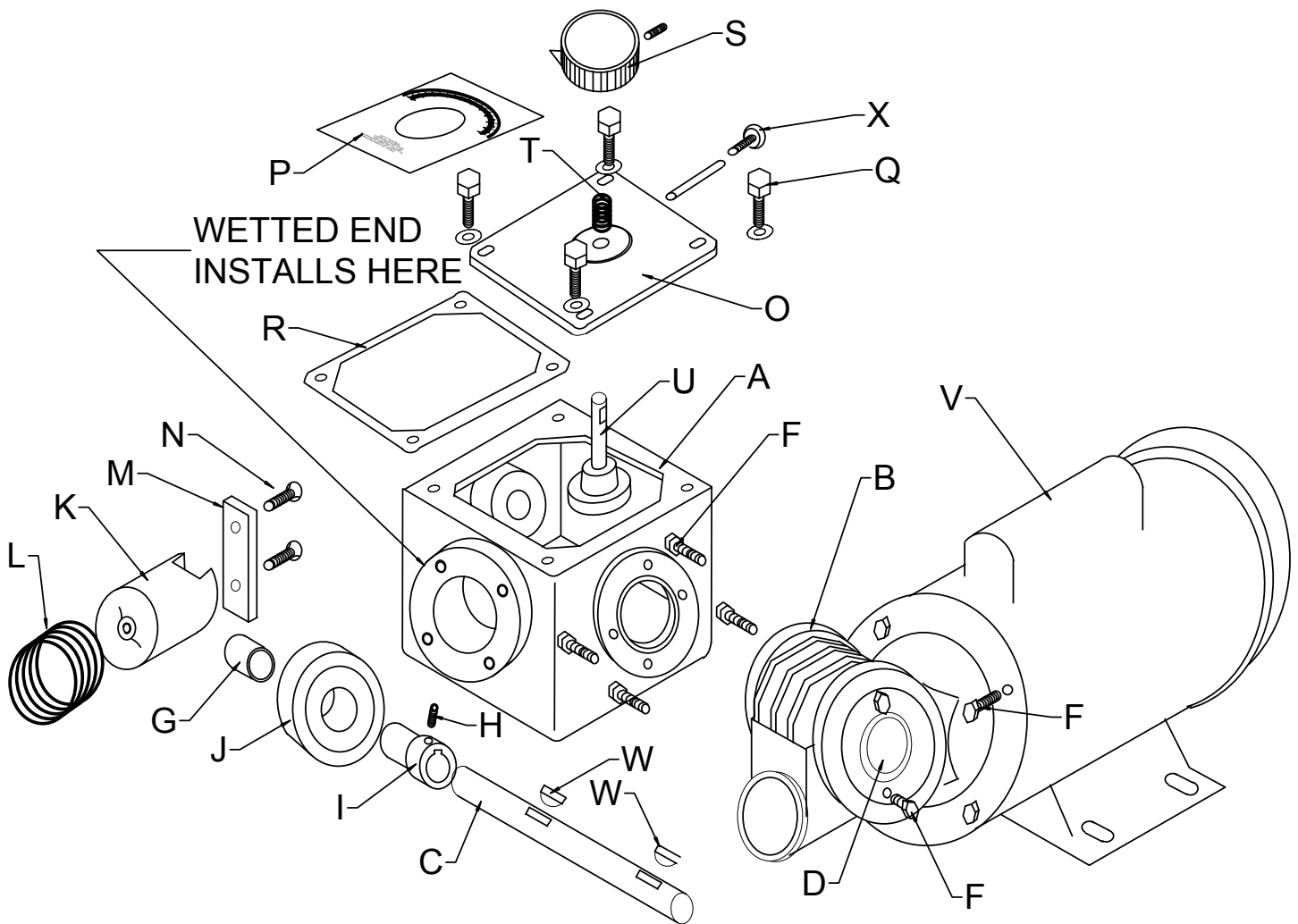

MADDEN Elkhart, IN, USA

- A. Diaphragm metering pump
- B. Tank
- C. Control valve
- D. Strainer
- E. Calibration column
- F. Union for piping installation to pump
- G. Pulsation dampener, chargeable type
- H. Pressure gauge
- I. Pressure relief valve, adjustable, diaphragm type
- J. Back pressure valve, adjustable, diaphragm type
- K. Vent line from calibration column
- L. Return line to tank from pressure relief valve
- M. Tank drain

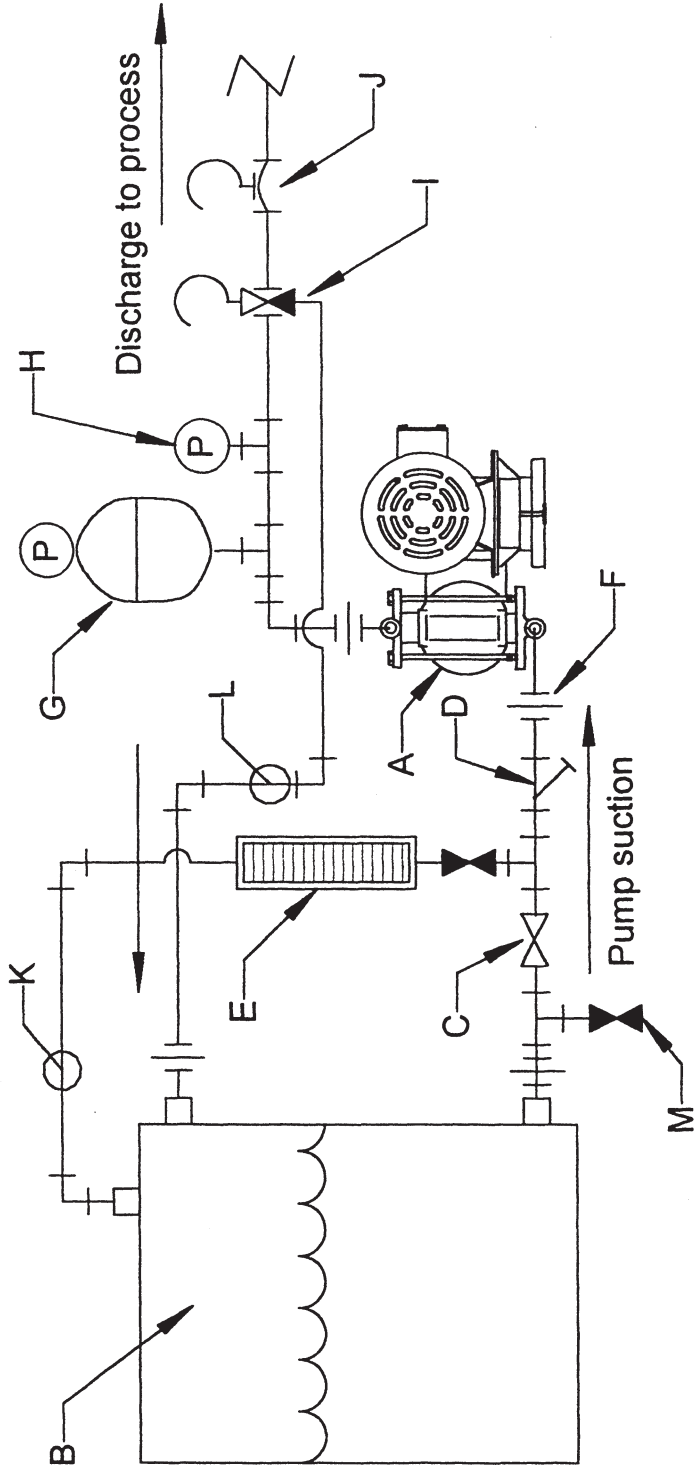

TYPICAL METERING PUMP INSTALLATION DIAGRAM

See Form No. M-316, Start Up Protocol, for installation instructions. Note, not all of the piping accessories shown above may be required.

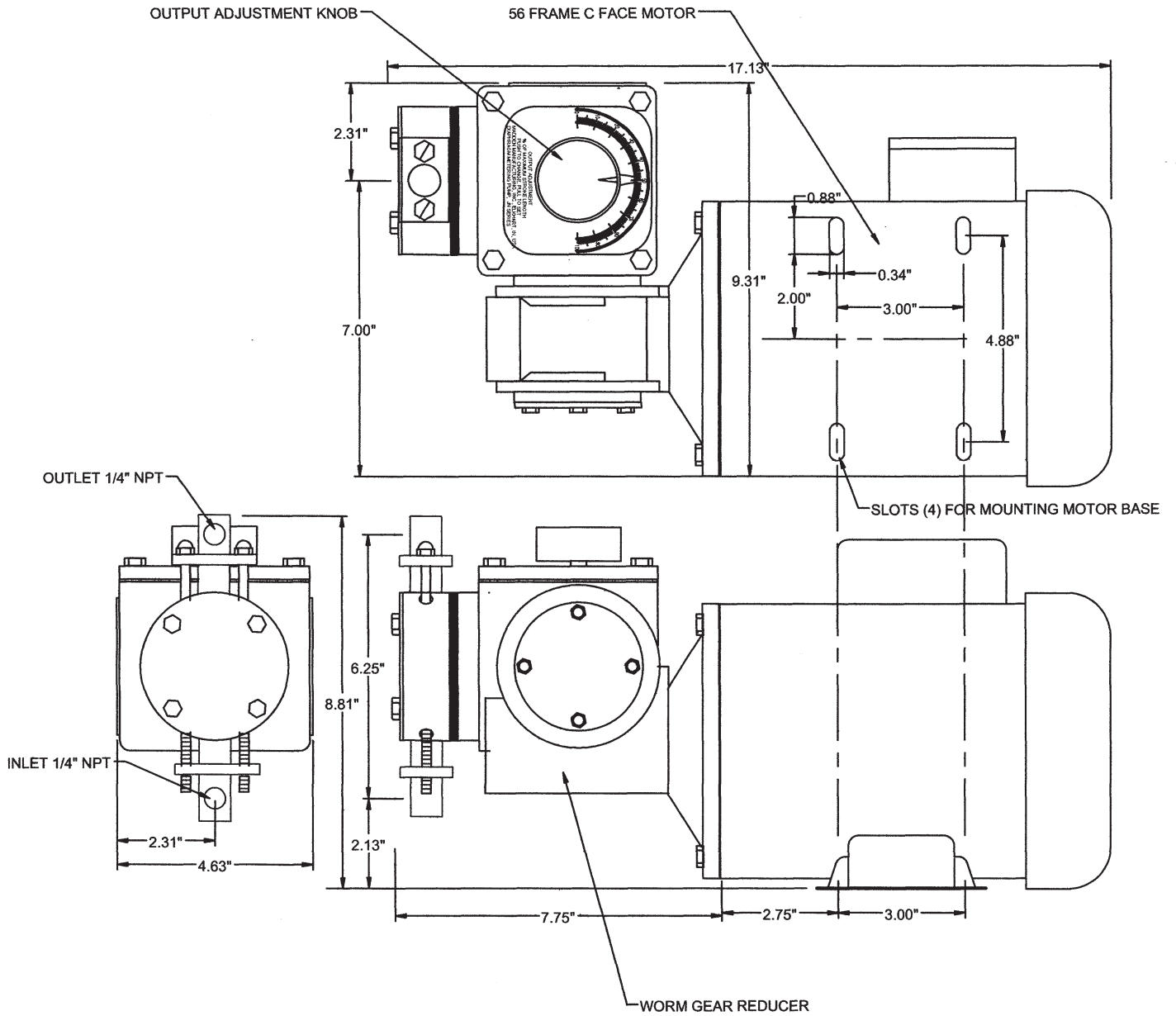

MADDEN
PUMP

P.O. Box 387 • 1317 Princeton Blvd. • Elkhart, IN 46516
 Phone (574) 295-4292 Fax (574) 295-7562
 email: info@maddenpump.com website: www.maddenpump.com

Form no. JN-MAN-11