

MADDEN PUMP

DIAPHRAGM METERING PUMPS

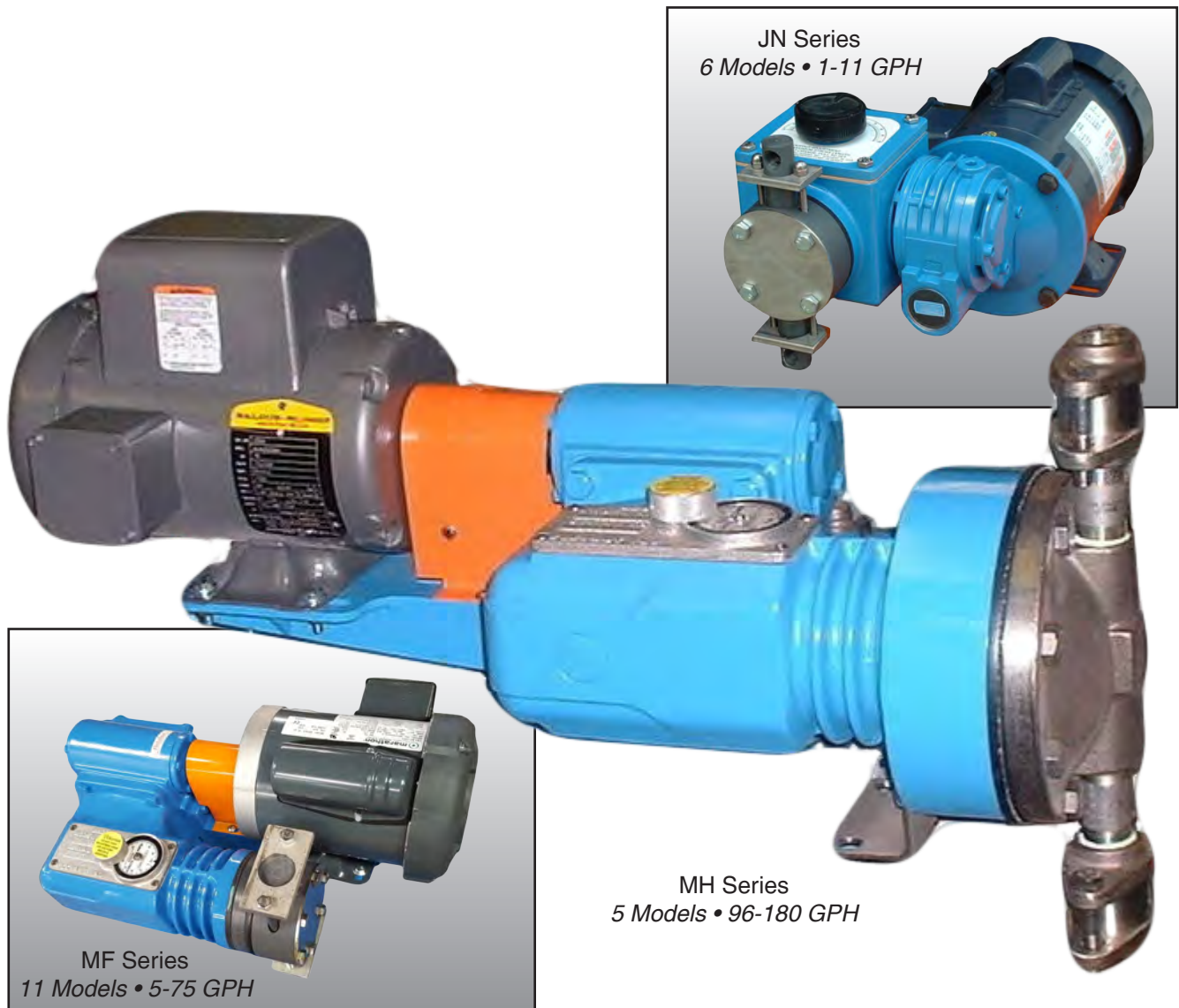

**Simple, Rugged and Accurate
Designed For Continuous Heavy Duty Service**

P.O. Box 387 • 1317 Princeton Blvd. Elkhart, IN 46515 USA
Phone: 574-295-4292 • FAX: 574-295-7562
E- mail: info@maddenpump.com • Website: www.maddenpump.com

MADDEN PUMP

Pump Part Number Form

Tel: 574-295-4292 - Email: info@maddenep.com

Pump Series	
JN	
MF	
MH	
Pump Heads	
1 - Simplex	
2 - Duplex	
3 - Triplex	
4 - Quadruplex	
Capacity - G P H	
01	JN
02	
04	
05	
07	
11	
05	MF
10	
18	
36	
60	
96	MH
125	
150	
180	
Valve Cap Sizes	
1 - 1/4" NPT	
2 - 3/8" NPT	
3 - 3/8" + M200 SLV	
4 - 3/4" NPT	

Solution Head	
S - 316SS	
P - P V C	
T - Teflon	
PP - PolyPro	
Diaphragm	
E - E P D M	
N - Neoprene	
H - Hypalon	
V - Viton	
TN - Teflon-Neoprene	
TH - Teflon-Hypalon (JN only)	
TV - Teflon-Viton	
Valve Balls	
A - Alloy 20	
C - Ceramic	
H - Hastelloy C	
S - 316SS	
T - Teflon	
V - Viton	
Valve Seats	
C - Ceramic	
E - E P D M	
N - Neoprene	
S - 316SS	
T - Teflon	
V - Viton	
DDB Double Diaphragm	
0 - (zero) - No DDB	
E - E P D M	
H - Hypalon	
N - Neoprene	
V - Viton	

Motor H P	
0 - (zero) - No Motor	
A - 1/3 HP	
C - 1/2 HP	
D - 3/4 HP	
E - 1 HP	
F - 1.5 HP	
G - 2 HP	
Motor Type	
S - Standard	
X - Explosion Proof	
W - Washdown Duty	
M - Mill & Chem Duty	
H - 50 Hz	
Motor Phase	
1 - Single Phase	
3 - Three Phase	

Epoxy-Poly Paint	
E - Epoxy-Polyurethane	
<i>(Enter only if applicable)</i>	

ex.)

MF1182

-

SNSNN

-

CS1E

Selection from each category

Z = Special or Custom

MADDEN DIAPHRAGM METERING PUMPS

Madden diaphragm metering pumps are designed for tough industrial jobs where chemicals must be pumped 24 hours a day, 365 days a year. Engineered materials are used for the wetted end to pump virtually any chemical, from acids to caustics. Even viscous liquids and suspended solids can be pumped with volume controlled accuracy.

■ ACCURACY

Repetitive accuracy of +/- 1% over a 10:1 turndown ratio is achieved with the stroke adjustment knob located conveniently on the top of the pump.

■ LONG SERVICE LIFE, LOW MAINTENANCE

The simple mechanically actuated diaphragm design eliminates pesky hydraulic systems and packing glands used in many metering pumps. Large bearings and shafts, continuously lubricated with a bath of oil give many years of reliable service. Precision bronze worm gears and steel worm drive shafts convert motor rpms to linear piston pumping power. Replacing worn parts is fast, simple, with common tools.

■ THREE PUMP SERIES

1. JN Series: 6 models from 1 – 11 GPH (4-42 L/hr), simplex, duplex and triplex pumps available.

2. MF Series: 11 models from 5 to 75 GPH (19-280 L/hr), simplex, duplex, triplex and quadruplex pumps available

3. MH Series: 5 models from 96 to 180 GPH (363-681 L/hr), simplex and duplex pumps available

■ RUGGED CONSTRUCTION

Madden pumps are heavy duty industrial grade, using standard industrial 56 frame motors and worm gear reducers to produce reliable pumping power designed to provide many years of reliable service. Heavy duty aluminum gear box and pump body castings, precision machined and bolted assembly. Wetted end parts made from a selection of corrosion resistant materials. Thick Nylon reinforced diaphragms for tough pumping service. Industrial grade 56 frame electrical motors are available to meet any enclosure and power supply requirements.

Frequently Asked Questions

1. What is the suction lift capability? Up to 10 feet, however the pumps have greater output with a flooded suction.
2. What are the viscosity limits? Madden MF and MH Series pumps work well with liquids up to 450 cps (2,000 ssu) viscosity. JN Series pumps are not recommended for high viscosity liquids.
3. What is the liquid temperature limit? 200 degrees F. is the limit for pumps with metal wetted end materials. Plastic wetted end materials have limits as low as 140 degrees F.
4. Is a back pressure on the discharge side of the pump required? Yes, a minimum of 15 psi greater than the suction pressure is required to allow the ball checks to close quickly for accurate pumping.
5. How is the output adjusted? Each pump has a stroke length adjustment knob located on the top of the pump body which permits the operator to manually adjust the output from 0 to 100%. The pumps are most accurate operating in the 10-100% range.
6. Is automatic pump control available? Madden pumps equipped with an optional variable speed drive controller and a variable speed motor can respond to a remote 4-20 mA or other signal to change the pump output by changing the motor speed. The only limit is the minimum stroking speed of 15 strokes per minute.
7. Does the pump have a leak detector? Madden pumps equipped with the Type DDB double diaphragm construction can be equipped for either visual or electric alarm signal actuation when a diaphragm leak is detected. This is an especially important feature when hazardous liquids are being pumped to prevent damage to the pump, personnel, and the environment.

CONSTRUCTION FEATURES - MF SERIES

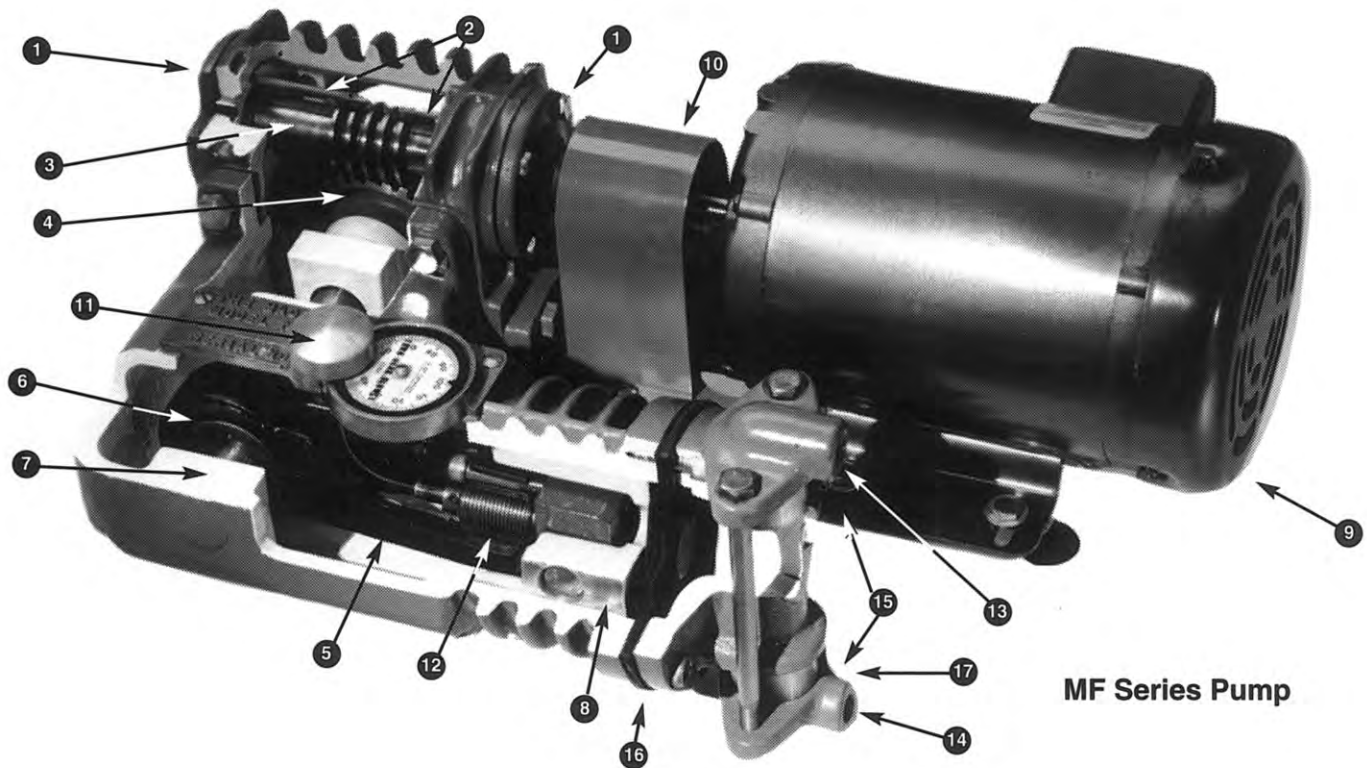

MF Series Pump

1. **Bearing Cap** - containing self-oiled tapered roller bearing.
2. **Oil Feed Tubes** - provides continuous supply of oil to bearings.
3. **Drive Shaft** - made from alloy steel, integral precision machined worm drive gear.
4. **Worm Wheel Gear** - made from extra heavy cast bronze, machined to exacting tolerances.
5. **Connecting Rod** - rugged, over-sized casting provides extra large bearing surfaces. Minimum wear - longer life!
6. **Eccentric** - extra large (1-7/8" diameter x 1-1/4" face) precision ground and hardened.
7. **1" Drive Shaft** - ground & polished, supported by 2 out-board and 2 in-board bronze bushings for extra rigid alignment.
8. **Piston** - 3" diameter x 3" long provides extremely large bearing surface. Floating in oil and moving with a short stroke for minimum wear.
9. **Motor** - premium quality with ball bearings and foot mount. Available in any enclosure or voltage. Standard motor is 1 or 3 phase, 1725 r.p.m., 56 frame TEFC. See page 5
10. **Flexible Coupling and Coupling Guard** - meets ASME B15.1 safety standard.
11. **"Micro-Control" volume adjustment.** The Stroke Adjustment knob and Dial Scale are conveniently located on the top of the pump. The Dial Scale is divided into one hundred calibrations. For quick, accurate adjustments, it is geared directly to the knob which also controls the piston movement via a flexible cable. *Adjustment is made only while the pump is running!*
12. **Stroke Length Adjusting Screw** - provides "lost motion" type volume adjustment.
13. **Outlet Piping Connection** - 3/8" or 3/4" NPT Valve Cap.
14. **Inlet Piping Connection** - 3/8" or 3/4" NPT Valve Cap.
15. **Check Valve - Inlet and Outlet Ball Type.** See page 3 for details.
16. **Diaphragm** - Heavy duty fabric reinforced, double diaphragm also available. See page 3 for details.
17. **Solution Head** - Vertical mounting assures clearance of entrained air & helps maintain agitation while minimizing precipitation of solids. With the diaphragm acting as a tough, flexible barrier, all working parts of the pump are protected from the fluid being pumped. See page 4 for construction materials available.
18. **Durable acrylic enamel finish** - for protection from environment. For superior corrosion resistance, an optional epoxy/polyurethane finish is available.

NOTE: MH Series Pump construction is identical to the MF Series shown above, except the MH Series uses a larger 4-1/2" diameter steel piston.

MF SERIES FEATURES

VALVES THAT CLOSE IN THE ROUGHEST SERVICE

Valves to Assure Accurate Pumping

Valve action governs the ability of a metering pump to perform with repetitive accuracy within a narrow range of tolerance. MF Series pump standard ball valves (see diagram) have large conical rubber seats molded in a variety of compounds. The seat cushions the ball check and grips it to assure a positive seal. The removable seat fits inside the valve body. Since rubber often resists abrasion and corrosion better than rigid materials, valve repairs are minimized.

Several other types of valves are available in the MF Series pumps. Spring loaded Type M-200 valves are used with polymers and other liquids with a viscosity up to 2,000 ssu (450cps). Cone type valves and Type M-115 rigid seat valves are also available.

JN Series pumps use double ball type valves with removable conical Teflon seats for repetitive accuracy at very low flow rates. MH Series pumps use conical shaped, glass filled Teflon, Ceramic or 316 stainless steel seats for high volume valve ball seating.

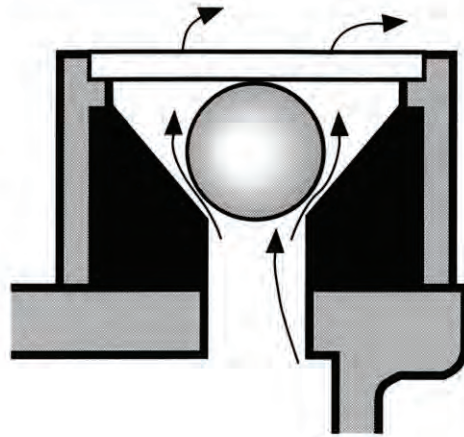

THE METRIFLOW DIAPHRAGM. . . TOUGH AS A TIRE

Tough, one piece diaphragms suck the liquid into the pump solution head and push it out again on the compression stroke. The molded rubber and Nylon fabric construction diaphragm for the MF and MH Series pumps are 1/4" thick. JN Series diaphragms are 3/16" thick. The molded-in diaphragm screw connects to the pump piston for positive suction action. Service life is maximized and fatigue minimized with the short stroke length used in MADDEN pumps, from .090" in the JN Series, to .380" in the MH Series. The contoured design of the diaphragm and the matching piston relieve stress on the diaphragm material. Several types of rubber are available for different liquids. Teflon faced diaphragms are available for highly corrosive material.

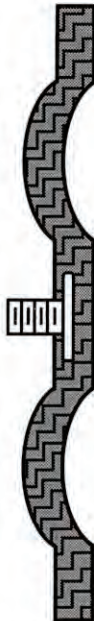

ADDED PROTECTION WITH DOUBLE DIAPHRAGMS

The optional Type DDB double diaphragm provides added protection from dangerous liquids. When the liquid being pumped is highly corrosive, the backup diaphragm of the Type DDB double diaphragm option will keep the liquid out of the pump body in the event of a leak in the primary diaphragm, allowing the diaphragm to be replaced before the pump is damaged. The Type DDB spacer has a 1/4" NPT connection. The optional MP 138 stainless steel leak detector switch can be used to activate an alarm signal or turn off the power to the pump for automatic leak protection. Alternatively, a clear tube can be installed for visual leak detection.

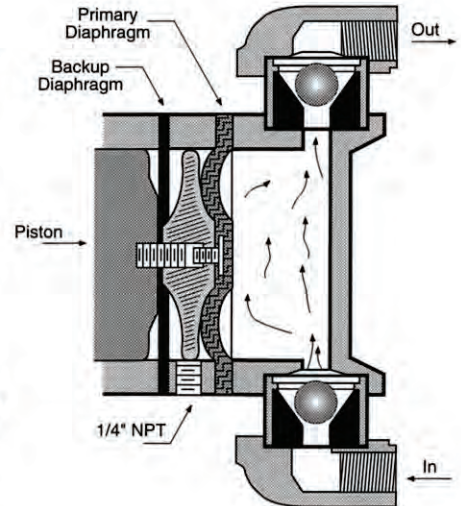

MADDEN DIAPHRAGM METERING PUMPS

Serving industries around the world for over 50 years.

Pump model and specification chart.

Simplex Pumps, (one pumping head) Duplex, triplex and quadruplex pumps also available.

Model No.	Output range GPH	Output range L/hr	Max pressure psi (bar)	Piping connections	Motor HP (kw)	Stroke speed, 1,725 rpm motor
JN101_A	0.1-1	0.38-3.8	250 (17.6)	1/4" NPT	1/3 (.25)	29 spm
JN102_A	0.2-2	0.76-7.6	250 (17.6)	1/4" NPT	1/3 (.25)	44 spm
JN104_A	0.4-4	1.5-15.1	250 (17.6)	1/4" NPT	1/3 (.25)	88 spm
JN105_A	0.5-5	1.9-18.9	250 (17.6)	1/4" NPT	1/3 (.25)	115 spm
JN107_A	0.7-7	2.6-26.5	250 (17.6)	1/4" NPT	1/3 (.25)	172 spm
JN111_A	1.10-11	4.2-42	250 (17.6)	1/4" NPT	1/3 (.25)	230 spm
MF105_A	0.5-5	1.9-18.9	300 (21.1)	3/8" NPT	1/3 (.25)	29 spm
MF110_A	1-10	3.8-37.8	150 (10.6)	3/8" NPT	1/3 (.25)	29 spm
MF110_C	1-10	3.8-37.8	300 (21.1)	3/8" NPT	1/2 (.37)	29 spm
MF118_A	1.8-18	6.8-68	150 (10.6)	3/8" NPT	1/3 (.25)	58 spm
MF118_C	1.8-18	6.8-68	300 (21.1)	3/8" NPT	1/2 (.37)	58 spm
MF136_A	3.6-36	13.6-136	150 (10.6)	3/8" NPT	1/3 (.25)	115 spm
MF136_C	3.6-36	13.6-136	300 (21.1)	3/8" NPT	1/2 (.37)	115 spm
MF160_A	6-60	22.7-227	80 (5.6)	3/8" NPT	1/3 (.25)	172 spm
MF160_C	6-60	22.7-227	160 (11.2)	3/8" NPT	1/2 (.37)	172 spm
MF160_D	6-60	22.7-227	250 (17.6)	3/8" NPT	3/4 (.56)	172 spm
MF190_C	7.5-75	28-280	35 (2.5)	3/4" NPT	1/2 (.37)	172 spm
MH196_D	9.6-96	36-363	150 (10.6)	3/4" NPT	3/4 (.56)	115 spm
MH1125_E	12-125	47-473	150 (10.6)	3/4" NPT	1 (.75)	172 spm
MH1150_F	15-150	57-568	150 (10.6)	3/4" NPT	1.5 (1.12)	172 spm
MH1180_E	18-180	68-681	50 (3.5)	3/4" NPT	1 (.75)	172 spm
MH1180_F	18-180	68-681	100 (7)	3/4" NPT	1.5 (1.12)	172 spm

For duplex pumps total output capacity when both outputs are combined multiply data above by 2.
 Maximum pressure for pumps with plastic pumping head is 150 psi.
 For output capacity using 50 Hz pump motor multiply data above by 0.833.

Wetted end materials available to resist corrosion.

Pump Series	Solution head				Diaphragm					Valve Balls					Valve Seats					
	316 SS	PVC	Teflon	Polypropylene	Neoprene	Hypalon	Viton	Teflon faced	Teflon/Viton	316 SS	Ceramic	Hastelloy C	Alloy 20	Teflon	Neoprene	Hypalon	Viton	Teflon	316 SS	Ceramic
JN Series	•	•	•		•		•	•		•	•	•		•				•		
MF Series	•	•	•	•	•	•	•	•	•	•	•	•		•	•	•	•	•	•	•
MH Series	•	•	•		•	•	•	•	•	•	•	•	•	•				•	•	•

MF SERIES PUMP OPTIONS continued

MOTORS AND VARIABLE SPEED DRIVES

- **Standard motors:** 1725 r.p.m., TEFC, 56 frame, 1/60/115-230 or 3/60/230-460 power.
- **Special motors available as an option:** Explosion Proof, Washdown Duty, Mill & Chemical Plant Duty, 50Hz, etc.
- **DC variable speed drive:** 20:1 turndown ratio, 4-20 mA signal input for automatic pump output control with a signal supplied by a process instrument. Controller box, available in TEFC and Wash Down Duty.
- **AC variable frequency drive:** Inverter duty, AC motor, controller box, 10:1 turndown ratio, 4-20 mA input control signal capability available with TEFC, Washdown Duty and Explosion Proof motors.

METRIFLOW MF SERIES - DIMENSIONS

SHIPPING WEIGHTS (Approximate)		
Motor H.P.	Simplex	Duplex
1/3	69 lbs.	100 lbs.
1/2	72 lbs.	110 lbs.
Pump Only	51 lbs.	69 lbs.

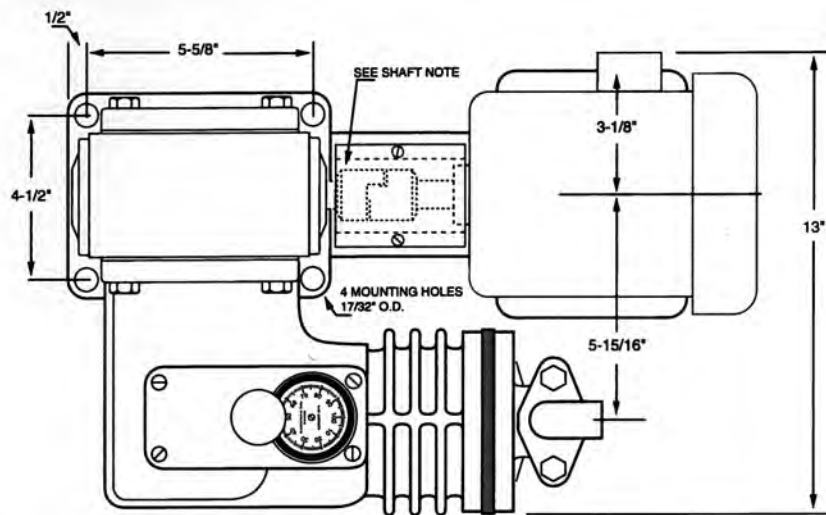

SHAFT NOTE:

Gear case shaft 5/8" O.D. and extends 13/16". Woodruff Key supplied requires coupling slot 3/16" x 3/32".

PIPING CONNECTIONS:

A. 3/8" N.P.T. thread except Model MF190C is 3/4" N.P.T. thread.

B. 3/4" N.P.T. vertical connections are available upon request.

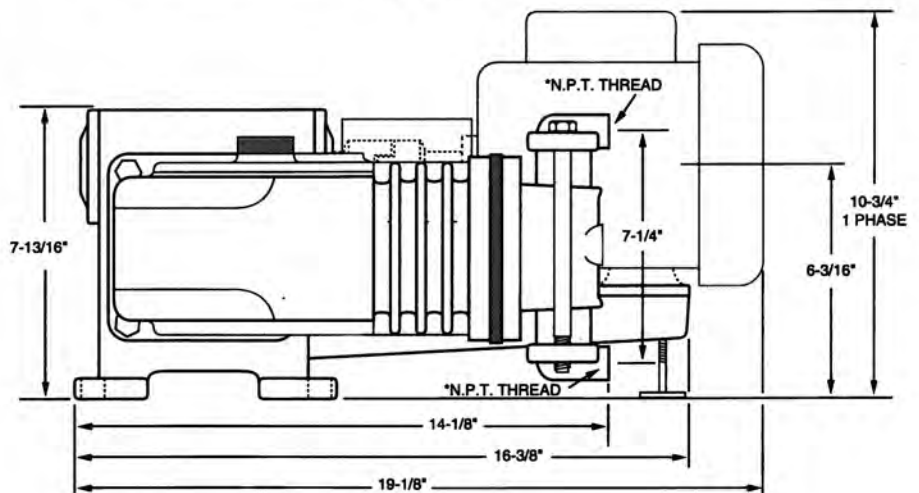

Metriflow Pumps

MH SERIES - 96 TO 360 GPH CAPACITY PUMPS

The MH Series pumps use a large 4-1/2" diameter piston, and longer stroke length, to create more displacement than the MF Series pumps offer. Other features for these mechanically activated diaphragm pumps are identical to the MF Series pumps (see cutaway photo on page 2). Five models with simplex capacity from 96 to 180 GPH are available while duplex models can double the pumping capacity. The manual output adjustment knob is located conveniently on the top of the pump body. For automatic output control with a 4-20 mA instrument signal, several variable speed drive packages of controller and motor are available. The worm gear reducer has integral steel worm drive shaft and a bronze worm gear, continuously splash-lubricated with ISO grade 460 worm gear reducer oil for extended gear and bearing life. Standard motors are 56 frame foot mounted, 1,725 rpm, TEFC. Repetitive accuracy is +/- 1%. Materials of construction in table on page 4. Contact the factory or consult our website at www.maddenpump.com for dimensional drawings.

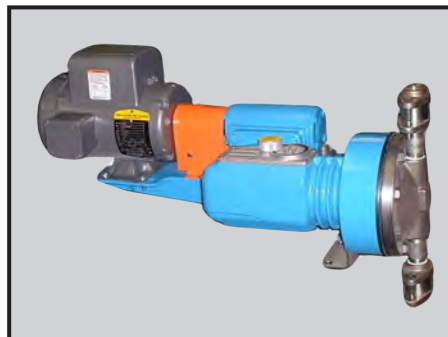

MH Series Pump (shown here) with PVC Solution Head and Type DDB double diaphragm construction.

JN SERIES - 1 TO 11 GALLON PER HOUR

These simple, rugged, accurate pumps are used in many industrial plants for injecting a controlled flow of highly reactive liquids such as acids, caustics and water treatment chemicals. Heavy duty industrial grade construction means these tough little pumps will deliver many years of trouble free 24-7-365 pumping. Simplex is shown. Duplex and triplex pumps also available.

- JN Series pumps are designed for especially low flow rates. Double ball checks with Teflon valve seats assure $\pm 1\%$ steady state repeatable accuracy over a 10:1 turndown range.
- Manual output control knob is located on top of the pump for easy access.
- Automatic pump output control is available for pumps equipped with a variable speed motor and a variable speed drive controller.
- Industrial grade worm gear reducer is permanently lubricated and C face mounted to the motor.
Precision internal pump parts run in an oil bath for extended service life. No external lubrication required.
- Double diaphragm option is available for superior protection from dangerous liquids.
- When equipped with the proper materials the JN Series pumps are excellent for pumping dangerous liquids such as acids, caustics and solvents.
- Standard motors are industrial grade 1/3 HP 56 frame, C face, foot mounted TEFC. Motors are available for explosion proof, washdown, and mill & chem plant duty, and for 1 or 3 phase, 50 or 60 Hz power.
- Tough fabric reinforced rubber diaphragms protect the drive train from the pumped liquid. The short .090" stroke with 2" diameter piston increases diaphragm life by reducing fatigue.



The JN Series replaces J Series and JR Series pumps. See data sheet no. JN11 for details.

STANDARD & CUSTOM CHEMICAL FEED SYSTEMS

Standard: Economical pre-engineered chemical feed systems with 30, 55 or 110 gallon polyethylene or 304 stainless steel tank. See brochure CF16 for details

Custom: Custom engineered chemical feed systems can be designed to meet practically any mixing and pumping need from high quality Madden components.

Madden also offers a pre-engineered boiler chemical feed system for boiler water treatment. Standard system can be modified to fit your specific needs.



ACCESSORIES

- **BACK PRESSURE CHECK VALVES:** Required when outlet connection pressure is less than 20 psi to enable pump valves to operate properly for accurate pumping. Sizes from 1/4" to 2", adjustable Teflon diaphragm with body material to match the pump construction.
- **RELIEF VALVES:** Required when outlet line may become closed to prevent over pressure on piping and pump components. Sizes from 1/4" to 2", adjustable, Teflon diaphragm with body material to match the pump construction.
- **PULSATION DAMPENER, AUTOMATIC/CHARGEABLE:** Eliminates pulsing flow and pressure peaking characteristic of piston type pumps. Available in sizes and material to match pump construction.
- **CALIBRATION CYLINDER:** Several sizes from 100 mL to 20,000 mL, clear PVC material, used to calibrate pump output at various adjustment knob settings.
- **LEAK DETECTOR SWITCH, PRESSURE TYPE:** Type 316 SS, used with type DDB double diaphragm to signal a leak in the primary diaphragm for prevention of damage from corrosive or dangerous liquids (Part # MP 138). Available with NEMA 4 or NEMA 4x enclosure.
- **PUMP MOUNTING BASE:** Heavy steel construction. Available for MF Series and JN Series.

MADDEN PUMP

Sold By:

1317 Princeton Blvd.
Elkhart, Indiana 46516
(574) 295-4292 Fax (574)295-7562Email:
info@maddenpump.com
Website: www.maddenpump.com

