

MADDEN PUMP

OPERATING GUIDE FOR USING REMOTE 4-20MA CONTROL

INPUT TO V.F.D:
(Typically) 4-20mA

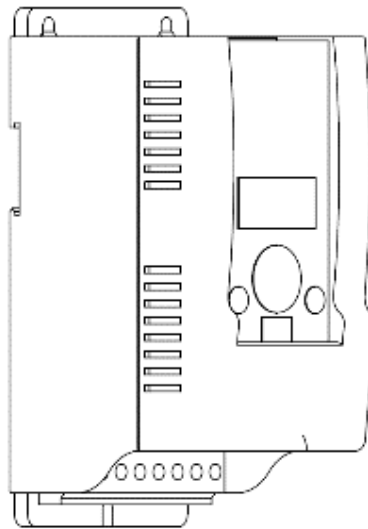

**OUTPUT TO
PUMP MOTOR:**
Variable Hz /
Frequency



JN Series

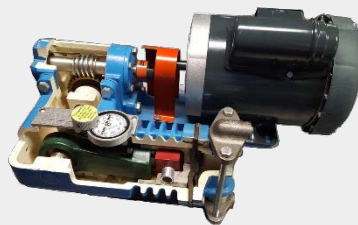

MF Series



MH Series

THE OPERATING PRINCIPLE

The cover page photograph highlights the robust Madden metering pump line. All three series, the JN, MF, and MH, use a rugged flexible diaphragm which is mechanically actuated by a substantial three-inch diameter piston and a 1,750 RPM A.C. electric motor. The stroke length is exceptionally short, increasing the service life of Madden metering pumps.

These pumps, classified as positive displacement, feature mechanically actuated diaphragm metering technology that delivers flow rates with an impressive accuracy and repeatability of +/- 1%.

The precision achieved in these pumps is primarily attributed to the ball-type check valves integrated into the suction and discharge valve assemblies. During the diaphragm's rearward stroke, the bottom (inlet) check valve's ball permits fluid entry into the solution head, while the top (outlet) check valve's ball firmly seats, preventing fluid or pressure from backflow. Conversely, with each forward stroke, the top check valve's ball allows fluid into the discharge line, and the bottom check valve's ball prevents backflow into the suction line.

An exploded view of the valve assembly is provided on the right for visual reference, emphasizing the importance of comprehending the operating principle for effective remote control of a positive displacement diaphragm pump. (The exploded view is an MF series SS wetted end, but principle of operation is the same for all pump series).

CONTROLLING THE PUMP AUTOMATICALLY / REMOTELY (4-20mA)

The standard method for remote flow rate control involves using a variable frequency drive connected to the electric motor in standard Madden pumps. This drive, equipped with a 4-20mA signal follower, modulates the electrical output sent to an inverter duty, A.C., 3-phase electric motor, thereby adjusting the pump's flow rate.

Maintaining a minimum of 15 strokes per minute is crucial for any positive displacement diaphragm pump with check valves to preserve repeatability and accuracy. Understanding this limit, we can determine the turn-down ratio for each Madden pump model by dividing its standard strokes per minute (with the motor running at a "full" 1,750 RPM).

For instance, the MF136_ pump strokes 115 times a minute with a 1,750 rpm electric motor. Using motor speed control via a frequency drive, the available turn-down ratio is calculated as $115 / 15$, resulting in 7.66 to 1.

Referencing the flow chart on the next page, one can gauge the pump's potential output. It's important to note that the chart was calibrated with 100 PSI discharge pressure, a piping assembly with approximately 20 feet of equivalent straight length, and several installed valves. Due to the check valve operating principle, the flow rate ranges remain linear and relatively consistent with various piping arrangements. However, on-site calibration is recommended for complete accuracy.

Considering the MF136 model as an example, using only a 4-20mA signal to remotely control the V.F.D. and, consequently, the pump motor, entails specific specifications:

1. **Available Turn Down:** The maximum SPM for an MF136_ is 115, and the minimum is 15, resulting in an available turn-down of 7.66 to 1.
2. **Relating to Motor Speed and Pump Output:** For the MF136_ pump with a turn-down of 7.66 to 1 using only motor speed control:
 - a. **Top End Output:** Approximately 36 GPH with the motor running at a full 60 Hz or 1,750 RPM.
 - b. **Low End Output:** Around 4.7 GPH (36 GPH / 7.66 ratio) with the motor running at 7.83 Hz or 228 RPM.
3. **Relating to Using a Remote 4-20mA Signal to Control Pump Flow:**
 - a. Firstly, a meter or transmitter must communicate with the PLC/DCS. From this signal, one can program a 4-20mA output to the Madden Pump motor's V.F.D.
 - b. If your application requires chemical injection to continuously follow another meter/transmitter output that fluctuates frequently, you can now use a wide range of mA outputs to instruct the motor to speed up and slow down accordingly. Remembering to stay within your pump model's turn down ratio (motor RPMs / Pump SPM).
 - c. **REMEMBER:** you are automatically/remotely controlling motor speed and thereby pump strokes per minute – Madden pumps do not have an option to remotely control stroke length adjustment or directly tell the pump precisely when/how many strokes to make.

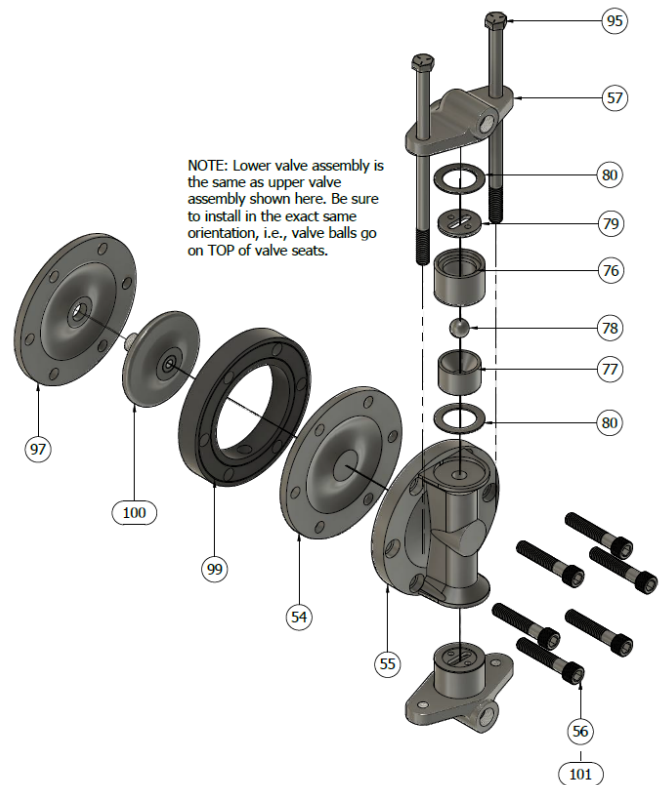

MADDEN PUMP FLOW RATE & TURN DOWN RATIO TABLE
SPECIFIC TO VARIABLE FREQUENCY DRIVE / MOTOR SPEED CONTROL

*Model Number	*Output Range (GPH)	*Output Range (LPH)	Standard Motor HP	S.P.M. @ 1750 RPM	Min. S.P.M.	Turn Down Ratio	Resulting Available Motor RPM Range
JN101-XXX-XXX	0.5 - 1	1.9 - 3.8	1/3	29	15	2 : 1	875 - 1750
JN102-XXX-XXX	0.66 - 2	2.5 - 7.6	1/3	44	15	3 : 1	583 - 1750
JN104-XXX-XXX	0.67 - 4	2.5 - 15.1	1/3	88	15	5.9 : 1	296 - 1750
JN105-XXX-XXX	0.65 - 5	2.5 - 18.9	1/3	115	15	7.66 : 1	228 - 1750
JN107-XXX-XXX	0.61 - 7	2.3 - 26.5	1/3	172	15	11.46 : 1	152 - 1750
JN111-XXX-XXX	0.7 - 11	2.7 - 42	1/3	230	15	15.33 : 1	114 - 1750
MF105-XXX-XXX	2.5 - 5	9.5 - 18.9	1/3	29	15	2 : 1	875 - 1750
MF110-XXX-XXX	5 - 10	18.9 - 37.8	1/3	29	15	2 : 1	875 - 1750
MF118-XXX-XXX	4.66 - 18	17.6 - 68	1/2	58	15	3.86 : 1	453 - 1750
MF136-XXX-XXX	4.69 - 36	17.7 - 136	1/2	115	15	7.66 : 1	228 - 1750
MF160-XXX-XXX	5.23 - 60	19.8 - 227	3/4	172	15	11.46 : 1	152 - 1750
MH196-XXX-XXX	12.5 - 96	47.4 - 363	3/4	115	15	7.66 : 1	228 - 1750
MH1125-XX-XXX	10.9 - 125	41.2 - 473	1	172	15	11.46 : 1	152 - 1750
MH1150-XX-XXX	13.08 - 150	49.6 - 568	1-1/2	172	15	11.46 : 1	152 - 1750
MH1180-XX-XXX	15.7 - 180	59.4 - 681	1-1/2	172	15	11.46 : 1	152 - 1750

MOTOR RPM NOTE: Always ensure your pump’s particular motor is able to run within the RPM range stated above. This table is intended to help quickly show how VFD’s (4-20mA signals) could be used to control a Madden pump’s output remotely/automatically - it is NOT confirming acceptable operating conditions for any and all motors. Always contact the motor manufacturer first if you have any concerns.

Turn Down Note: The turn down ratios listed in the table above are when using a variable frequency drive to control pump motor speed only. All Madden pumps also have a manual stroke length adjustment knob (which cannot be controlled remotely via 4-20mA), which provides an additional 10:1 turn down capability.

***Output Range:** Similarly to the turn down note above, the output ranges stated are per V.F.D. motor speed control only. These values assume the integral, manual stroke adjustment knob is set to 100 on the dial scale. If the stroke adjustment was turned down to 50 on the dial scale for example, then the output ranges above would be divided in half.

Positive displacement pumps have linear output per pressure and/or stroke length changes. Within reason, the operator can assume the stroke length knob setting (0, 10, 20, 30... 90, 100) will yield that percentage value of the max flow rates stated in the table.

Additional Flow Rate Notes: (1) Standard motor speed is 1,750 RPM @ 60 Hz to achieve the above flow rates. For 50 Hz motors running at 1,450 RPM, multiply the above flow range by 0.833. (2) Flow rate ranges are per pumping head, double (triple, or quadruple) total output if using a duplex, triplex, or quadraplex pump design. (3) For applications that will run on the higher end of the pressure ranges and/or are dosing higher viscosities (250+ cPs), Madden recommends increasing “standard” motor HP one fractional size.

OTHER LITERATURE & IMPORTANT INFORMATION: For more details on pump models see our individual JN, MF, and MH data sheets and operator’s manuals. These documents will provide dimensional drawings, troubleshooting and startup guidance, and additional specifications for each pump model.

For further assistance or additional details please do not hesitate to contact our factory.



PO BOX 387, ELKHART, IN 46515
 1317 PRINCETON BLVD, ELKHART, IN 46516
 PH: 574-295-4292 || FAX: 574-295-7562
 EMAIL: INFO@MADDENPUMP.COM || WEBSITE →

